

- ◇ **FBG flow sensor**
- ◇ **No electronics, zero power, EMI immune, suitable for use in hazardous areas**
- ◇ **Dense multiplexing capability**
- ◇ **Multiple km signal integrity for remote measurements**
- ◇ **Designs available for 1" to 12" lines**
- ◇ **Same unit can measure flow and density in liquid/gas/steam**
- ◇ **Suitable for saturated steam (100 bar / 312°C)**

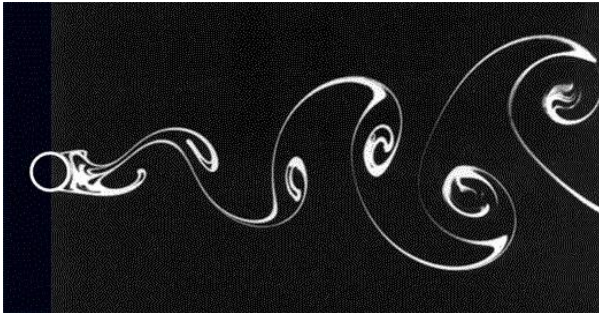

Vortex shedding over a bluff body

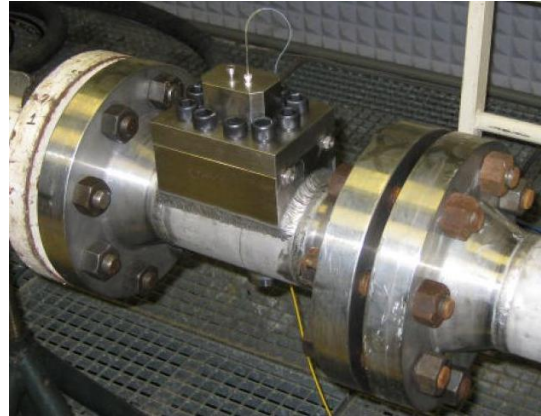

SmartFlow sensor

SmartFlow is a joint development between Smart Fibres UK and TNO Netherlands

Vortex shedding measurements operate by measuring the pressure variations on a 'bluff body' resulting from the turbulent flow over it.

Traditional vortex shedding flow meters have used piezo electric sensors which require associated electronics. The SmartFlow sensor combines vortex shedding flow measurement techniques with FBG sensing to provide a flow meter that is capable of being used in hazardous areas without expensive Ex or IS safety measures. SmartFlow meters can be used in a multi-drop configuration on one fibre as each meter uses different wavelengths. Optical fibre has very low losses so the flow meters can be used in positions remote to the instrumentation.

The SmartFlow has the following advantages in addition to the conventional vortex flowmeter:

- Practically unlimited signal processing capability, enabling robust and advanced meter & process diagnostics
- Can reliably be deployed in extreme & remote environments (i.e. subsea).
- No local electronics, making the meter extremely suitable with respect to explosion safety
- Multi-drop, possible to read 10-20 flowmeters with one single fiber
- Maintenance free concept

Advantages of the conventional vortex flowmeters are:

- No moving parts to wear
- No routine maintenance required
- Can be used for liquids, gases, and steam
- Stable long term accuracy and repeatability
- Lower cost of installation than traditional orifice-type meters
- Large turn-down ratio
- Applicable to a wide range of process temperatures
- Available for a wide variety of pipe sizes

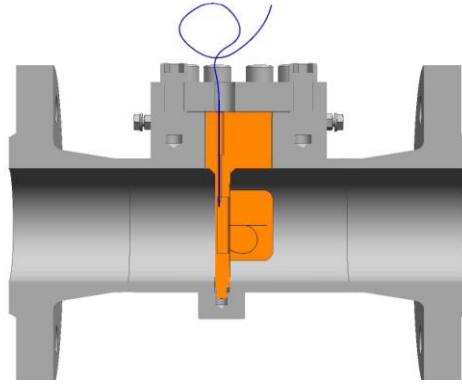

Cutaway diagram showing the vortex flow meter sensing elements.

Performance highlights

Accuracy

The SmartFlow sensor was tested in dry gas at pressures between 1 and 40 bar, showing its linear performance at various pressures, and achieving high accuracy across a range of Reynolds numbers.

Flow meter performance

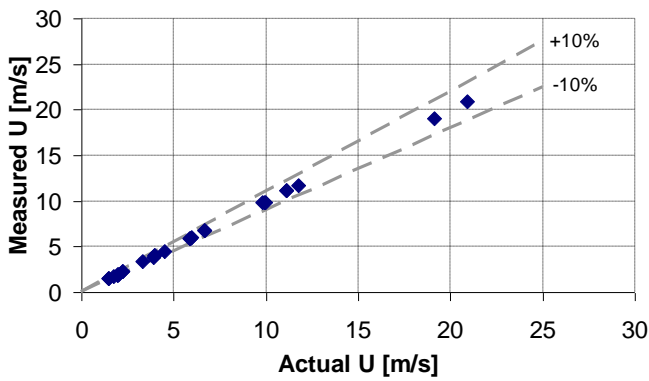

Flow meter error

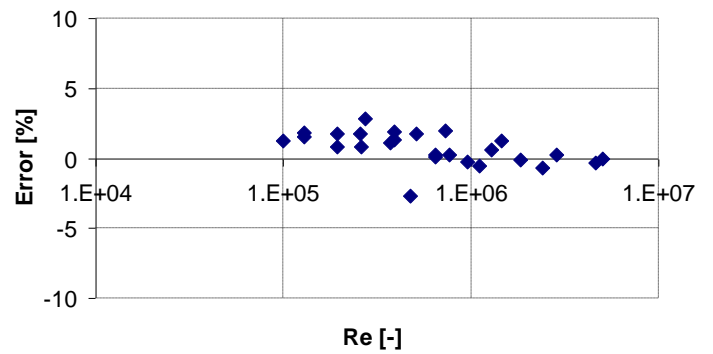

The meter was also tested in wet gas at up to 30% mass fraction of liquid, achieving accuracies better than 10% for wet gas.

Flow measurement errors

